

Lower Hold Volume Arrangements
747 Freighter

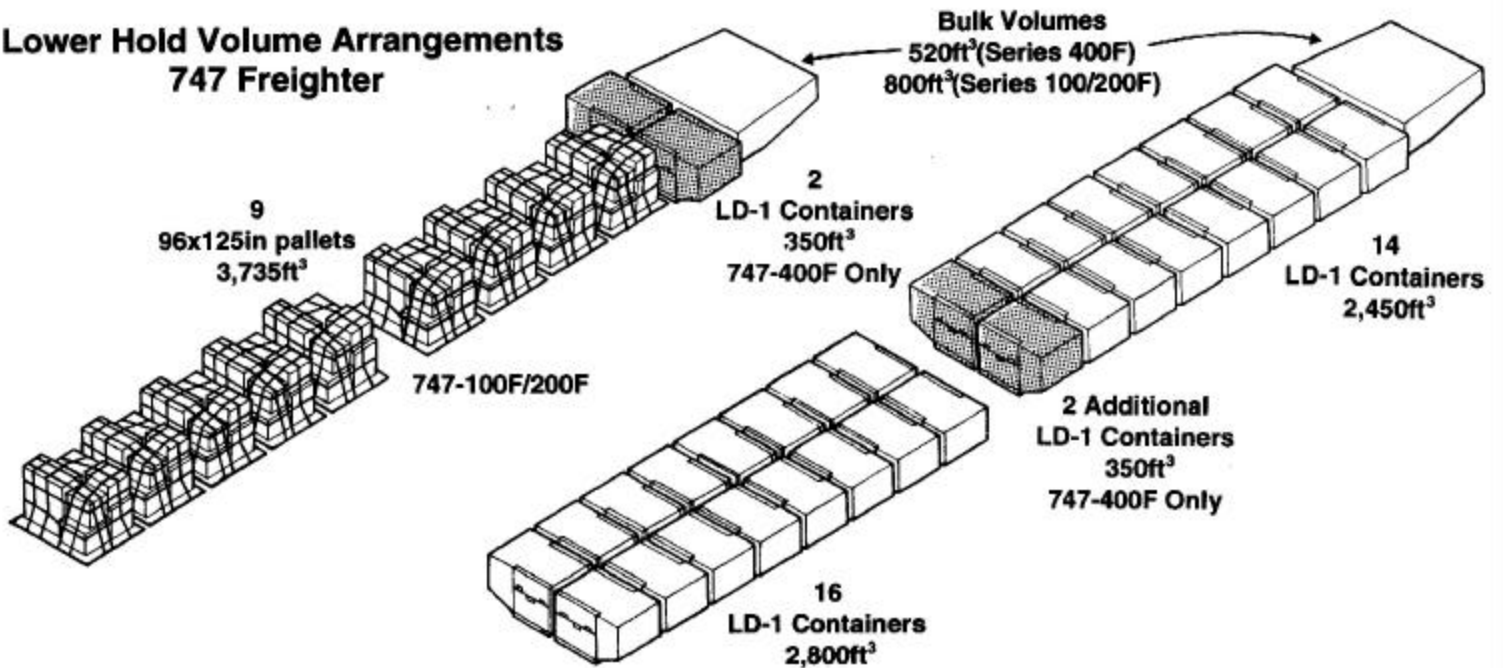

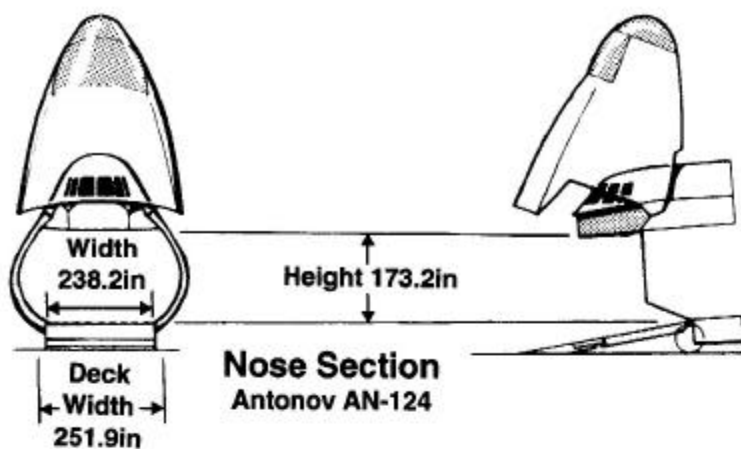

Cross Section
Antonov AN-124

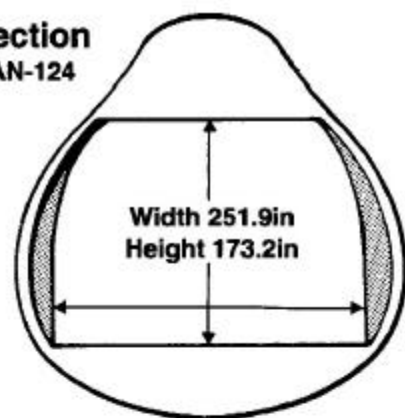

Cargo Door Openings
Antonov AN-124

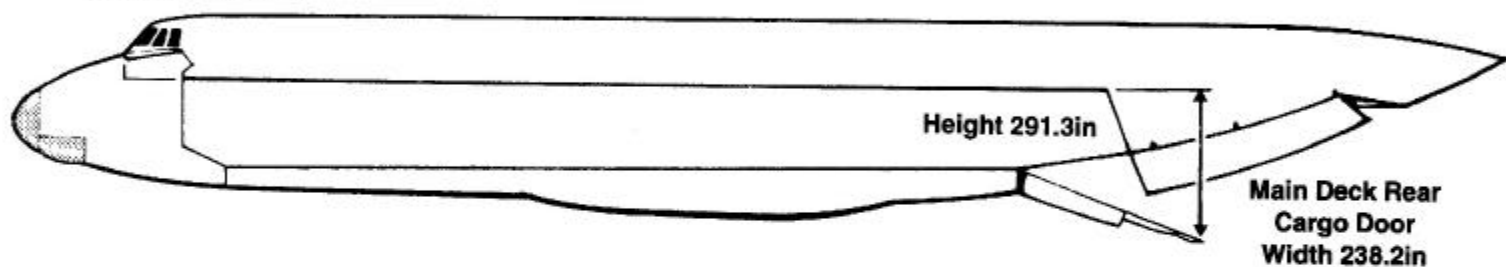

Main Deck Cabin Layout
Antonov AN-124

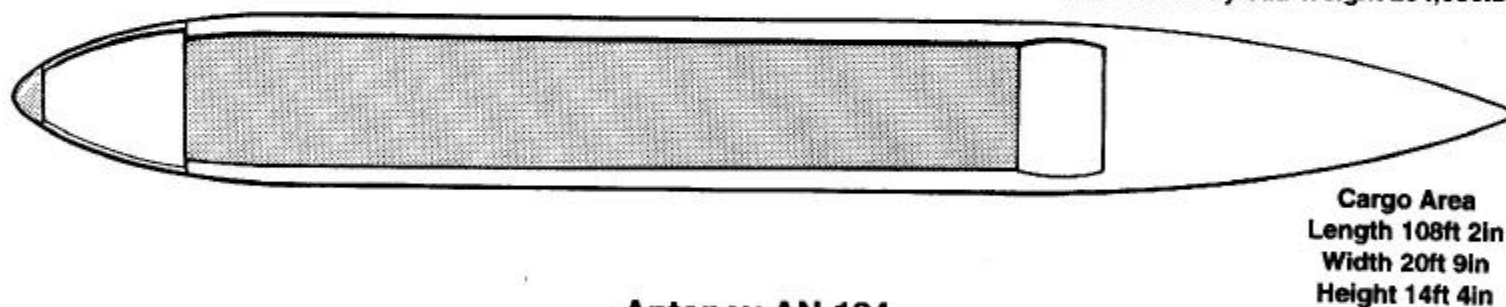

Antonov AN-124
Payload-Range Comparison

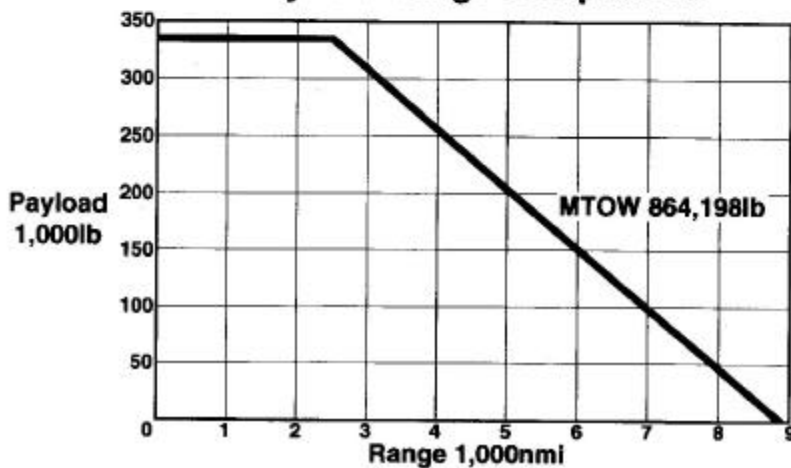

Cross Section
Ilyushin IL-76

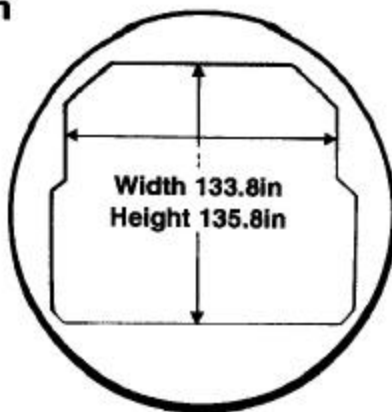

Cargo Door Openings
Ilyushin IL-76

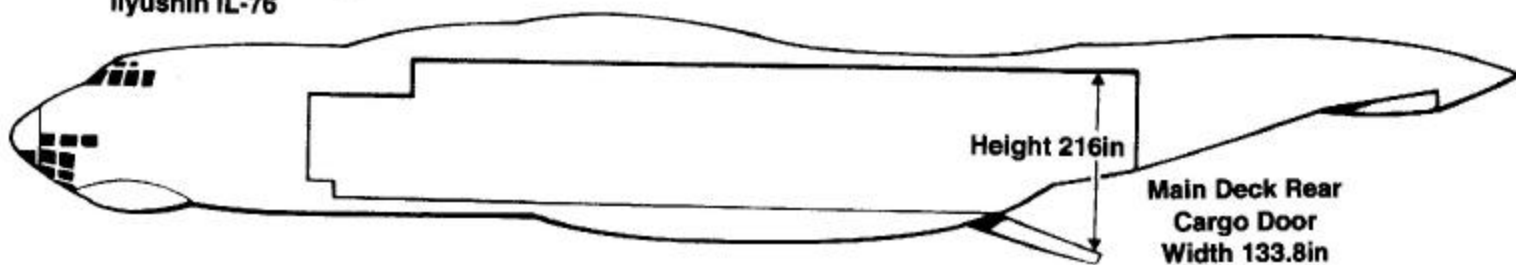

Main Deck Cabin Layout
Ilyushin IL-76



Cargo Area
Length 80ft 0in
Width 11ft 1in
Height 11ft 3in

**Ilyushin IL-76MD
Payload-Range Comparison**

